



PERFORMANCE DATA SHEET

Meets or exceeds MEPS, as described by the US DOE in docket 10CFR431 and NRCan's Amendment 14

Catalogue #: **MQS-8012-S3**

HP	kW	Voltage	S.F. @ 60Hz	EFF.	P.F.	Frame	Design	L.R. Amps
1	0,75	230 / 460	1,15	77,0%	0,840	80	B	15

60 Hz								Code	F.L. RPM
FLA									
208	230	416	460	480	575	600		K	3470
/	2,88	/	1,44	/	/	/			

50 Hz									
FLA			S.F. @ 50Hz	Efficiency	Power Factor	Code	F.L. RPM		
190	380	415							
3,5	1,75	/	1,00	75,5%	0,86	K	2900		

Wgt. Lbs	PH	Duty	Insul. Class	Amb.	Elevation	Temp. Rise° C
34,1	3	Cont.	F	40°C	1000M (3300 Ft)	55

% Efficiency		% Power Factor		Torque		Winding Resist. Ω	Safe Cold Start (Secs)
Full Load:	77,0%	Full Load:	0,84	Full Load Ft/Lbs	1,5		
3/4 Load:	73,8%	3/4 Load:	0,80	Locked Rotor %	300		
1/2 Load:	67,0%	1/2 Load:	0,71	Break Down %	360	/	20

Rotor Inertia Wk2 Lb-Ft2	Max Load Inertia Wk2 Lb-Ft2	Shaft Material	Frame Material	DE Bracket Type	ODE Bracket Type	Enclosure	NEMA Rating	Lead Wire Size
/	/	Stainless Steel 304				TENV	IP66	/

Ball Bearings		Grease	Mount Type	Orientation	Paint	Sound Pressure @ 3FT	Sound Power
DE	ODE						
6204	6204	Sealed Bearings	Rigid	Horizontal	-	/	/

Inverter Duty. Motor meets MG1 parts 31.4.4.2	Constant Torque Range	Variable Torque Range	Constant HP RPM
	10:1	20:1	1

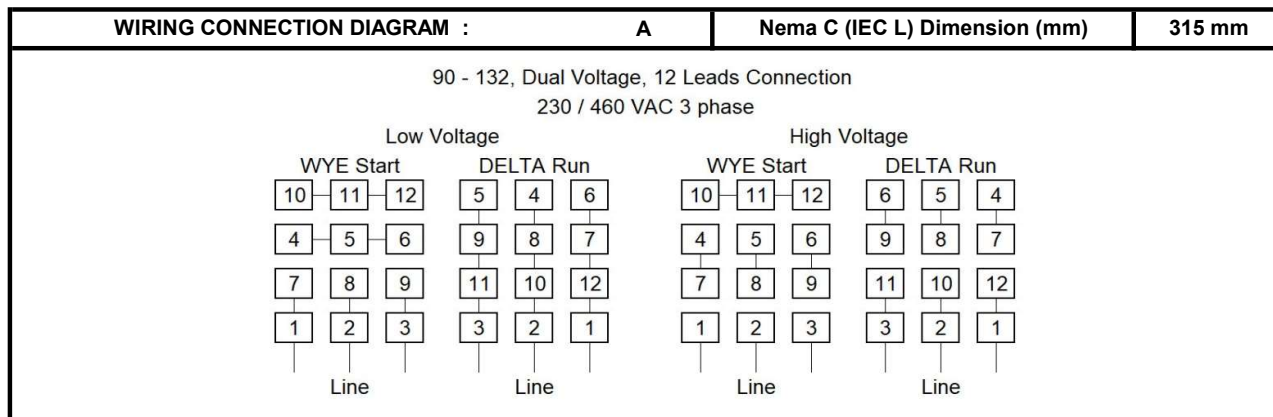

Date: 2023-12-21
 Customer: _____
 Contact: _____
 Submittee: J.C. Lavallée

Catalogue #: MQS-8012-S3

Meets or exceeds MEPS, as described by the US DOE in docket 10CFR431 and NRCan's Amendment 14

HP	VAC	RPM	Enclosure	Frame	Frequency	Design	Poles	LR Code Letter	Insulation Class	Temp. Rise °C
1	460	3470	TENV	80	60	B	2	K	F	55
	0Hz	6Hz	15Hz	30Hz	45Hz	60Hz	75Hz	90Hz	105Hz	120Hz
Amps	1,44	1,44	1,44	1,44	1,44	1,44	1,44	1,44	1,44	1,44
RPM	0	347	867,5	1735	2602,5	3470	4337,5	5205	6072,5	6940
Torq ft.lb	1,21	1,21	1,51	1,51	1,51	1,51	1,21	1,01	0,86	0,76
Peak Tq ft.lb	2,12	4,24	4,24	4,24	4,24	4,24	3,39	2,83	2,42	2,12
HP	0	0,1	0,3	0,5	0,8	1,0	1,0	1,0	1,0	1,0

	Locked Rotor	Pull-Up	Breakdown	Rated Load	Idle	Duty	S. F.	Ambient	Elevation	dBa @ 1M
Speed (RPM)	0,0	1512	2880	3470	3600	Cont.	1,15	40°C	3,300 ft	/
Current (Amps)	15,0	12,8	8,9	1,4	0,7	VFD Rating: Meets MG1 parts 31.4.4.2				
Torque (ft-lbs)	4,5	3,9	5,4	1,5	0,0	C.T.	10:1	V.T.	20:1	

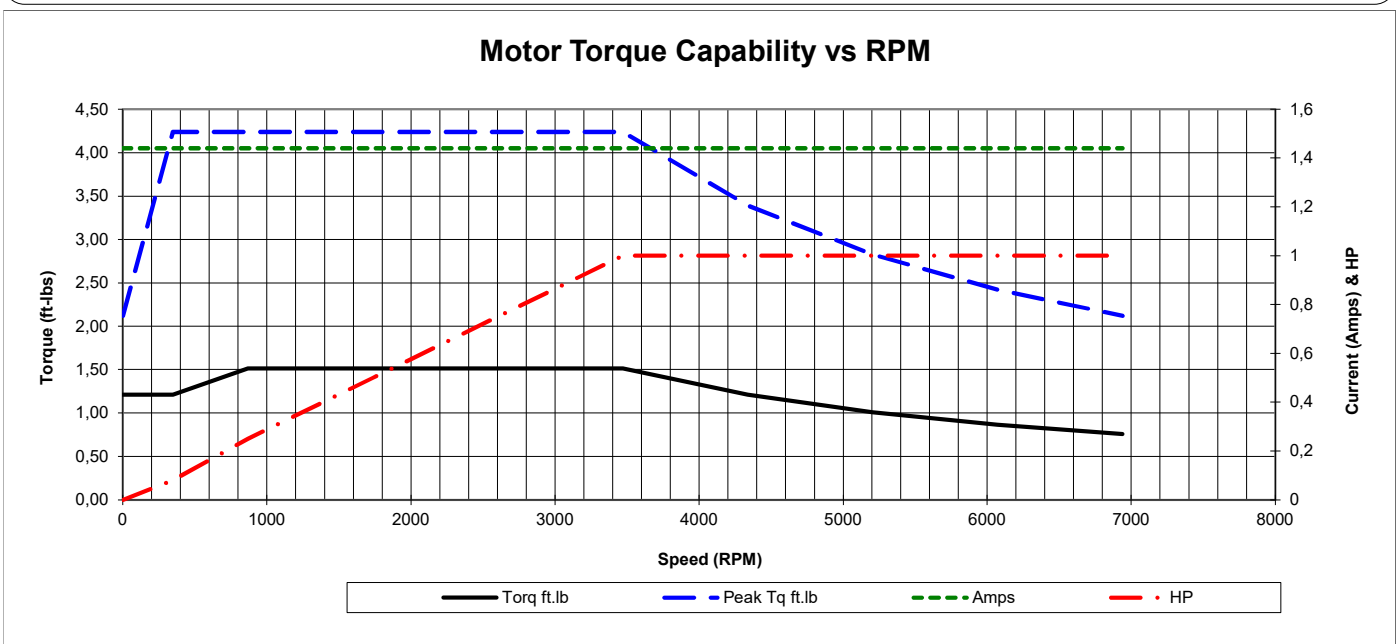
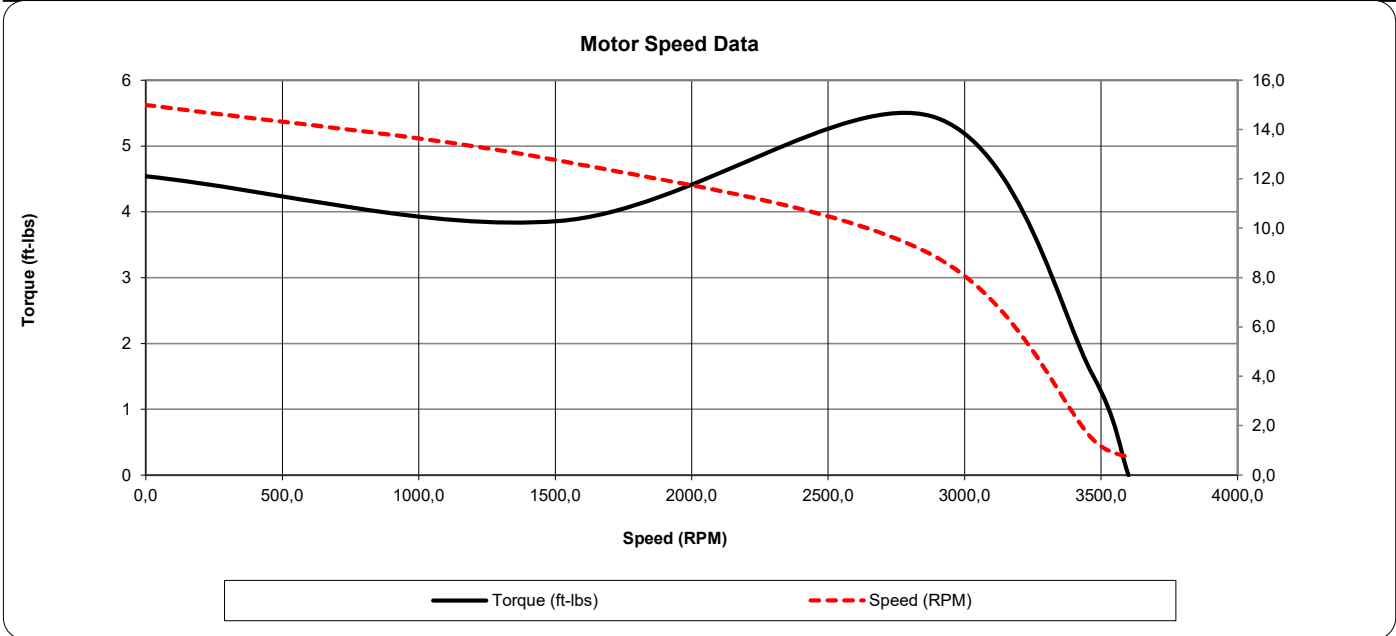

Date: 2023-12-21
 Customer: _____
 Contact: _____
 Submittee: J.C. Lavallée

Catalogue #: **MQS-8012-S3**

Meets or exceeds MEPS, as described by the US DOE in docket 10CFR431 and NRCan's Amendment 14

HP	VAC	RPM	Enclosure	Frame	Frequency	Design	Poles	LR Code Letter	Insulation Class	Temp. Rise °C
1	460	3470	TENV	80	60	B	2	K	F	55

Load %	0%	25%	50%	75%	100%	125%	150%
Amps	0,72	0,94	1,08	1,22	1,44	1,80	2,16
Torq ft/lbs	0	0,37	0,74	1,12	1,51	1,91	2,31
RPM	0	3567,5	3535	3502,5	3470	3437,5	3405
Eff	0	58,75	66,99	73,84	77,00	75,89	73,72
PF	0	36,1	71,4504	80,136	84,0	85,7	88,2

	Locked Rotor	Pull-Up	Breakdown	Rated Load	Idle	Duty	S. F.	Ambient	Elevation	dBA @ 1M
Speed (RPM)	0	1512	2880	3470	3600	Cont.	1,15	40°C	3,300 ft	/
Current (Amps)	15	12,8	8,9	1,44	0,72	VFD Rating: Meets MG1 parts 31.4.4.2				
Torque (ft-lbs)	4,54	3,86	5,45	1,51	0,0	C.T.	10:1	V.T.	20:1	

